

## S2001/S3001 Industrial UPS Series

SATRON S2001/S3001 series are Industrial, Heavy Duty ON-LINE Double Conversion UPS designed to supply critical AC Loads with stabilised continuous voltage. Products can be easily customized depending on the peculiar Customer request. Transformer for AC/DC galvanic separation and static and manual By-Pass is included



### FEATURES

- Industrial layout
- Easy maintenance
- Front access
- LCD Multifunctional Control Panel
- Mimic Pane
- SCR 6 pulse Technology (Rectifier)
- IGBT Technology (PWM) (Inverter)
- Remote Signalization via SPDT contact
- Temperature compensation of battery voltage
- Insulation: input/output galvanic insulation

### MAIN OPTIONS

- 12 Pulse rectifier
- AC & DC Distribution panele
- Internal lighting
- Internal heater
- AC/AC voltage regulator
- Bypass line isolator transformer
- Redundant ventilation
- Dual Parallel Operation
- Communication Port: USB or RS485 or Ethernet TCP/IP with MODBUS Protocol

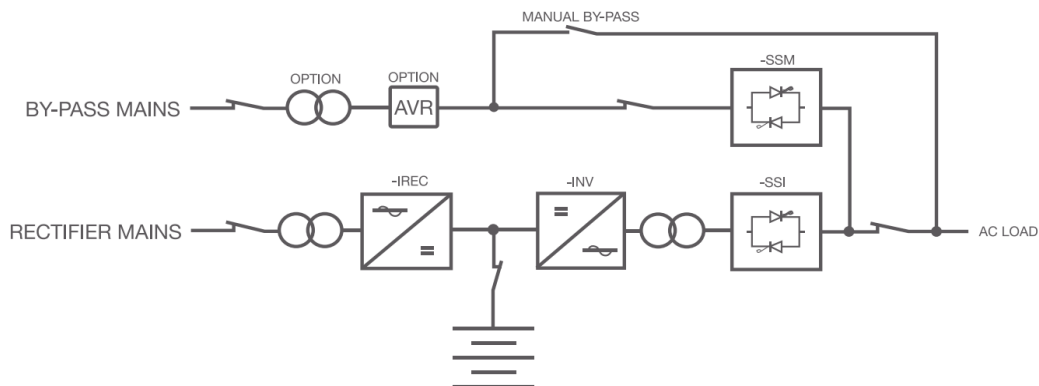

Single Line Diagram

Technology: Double Conversion on-line  
 Power rating: 5kVA to 50kVA  
 Input: 400V 3Ph  
 Output: 230V 1Ph  
 Battery Volatge: 110Vdc/220Vdc

## S2001 UPS 3Ph/1Ph Technical Specifications

Size (kVA) cosφ= 0.8	5	10	15	20	25	5	10	15	20	30	40	50	
<b>AC Input</b>													
Rated Voltage Vac	380/400/415Vac +/-10% 3Ph 50/60Hz (other as option)												
Power Factor	0,8 @ full load												
THD	THD ≤ 30 % typ.												
<b>AC Output</b>													
Output Voltage Vac	230 Vac 1Ph 50/60Hz (other as option))												
By pass input voltage	230 Vac 1Ph +/-10% (other as option))												
Harmonic Distortion	<2 % with linear load/ <5% with nonlinear load												
Crest factor	3:1												
Overload	105% permanent - 125 % for 10 min. - 150 % for 1min. - 200 % for 100ms												
Static Stability	+/- 1%												
Dynamic Stability	+/-5 % (80% load step) with recovery to 2 % in 40ms												
<b>DC Link</b>													
DC Voltage	110Vdc (90 - 150 )						220Vdc (180 - 300)						
Battery voltage	Floating: 2.27 (VRLA), 2.2÷2.3 (VLA), 1.4÷1.5 (Ni-Cd) V/cell Boost: 2.4÷2.45 (VLA), 1.5÷1.65 (Ni-Cd) V/cell Equalizing: up to 2.35 (VRLA), up to 2.7 (VLA), up to 1.7 (Ni-Cd) V/cell												
Charging current	4	8	12	16	20	2	4	6	8	12	16	20	
<b>Control &amp; Signalisation</b>													
Microprocessor	High Performance 8-Bit Microcontroller with Advanced RISC Architecture												
LCD Pane	Backlit graphic LCD for Meters, Alarm/Status messages, History events & Parameters Settings (password protected)												
Signalling LED	Inverter normal (green), Inverter fault (red), Rectifier normal (green), Rectifier fault (red)												
Acoustic Signa	Buzzer												
MIMIC Panel	Principle block diagram of the UPS with 9 integrated LED												
Volt free signalling contacts	AC input supply failure, Rectifier failure, DC voltage LOW/HI, Battery discharging, Battery disconnected, Inverter failure, Inverter overload, Inverter over temperature, AC output voltage LOW/HI, Ventilation failure, DC hearth fault (option)												
<b>Environmental conditions</b>													
Operating Temperature	0°C + 40°C not condensing												
Storage Temperature	: -20°C to +70°C												
Relative Humidity	≤ 95% a 40°C												
Altitude	≤ 1000 m without derating												
Audible Noise	< 65 –70 dB (A) at 1 m												
Efficiency At Full Load	≥ 88%												
MTBF	140.000 hr at 30 °C												
<b>Mechanical Characteristics</b>													
Cabinet	Free standing, floor mounting, Steel sheet Enclosure - Front door with handle (double rods)												
Steel thickness	Frame 2mm, Door & Sides 1.5mm, Rear & Roof 1.2mm												
Cooling method	Cabinet: Natural - Semiconductor heat sink: Fan assisted (temperature-controlled)												
Access	Front door												
Cable entry	From bottom / Other on request												
Degree of protection	IP20 / Other on request												
Painting / Colour	Epoxy-polyester thermosetting powder coating / RAL 7035												
Dimensions (mm)	W	800	1000	1000	1400	1600	800	800	1000	1200	1400	1600	1800
	D	800	800	800	800	800	800	800	800	800	800	800	800
	H	1900	1900	1900	1900	1900	1900	1900	1900	1900	1900	1900	1900

### Standards

- Quality and management system: ISO 9001 – 2008 ISO 14001 – 2004
- Safety: IEC EN 50178 IEC EN 62040 – 2 BS OHSAS 18001-2007
- CE Conformity: Yes
- EMC: IEC EN 61000-6-2, 61000-6-4, 62040-1
- Semiconductor Convertors: IEC EN 60146-1-1, 60146-1-3, 60146-2

Technology: Double Conversion on-line  
 Power rating: 5kVA to 80kVA  
 Input: 400V 3Ph  
 Output: 4000V 3Ph  
 Battery Voltage: 110Vdc/220Vdc

### S3001 UPS 3Ph/3Ph Technical Specifications

Size (kVA) cosφ= 0.8	5	10	20	30	40	10	20	30	40	50	60	80	
<b>AC Input</b>													
Rated Voltage Vac	380/400/415Vac +/-10% 3Ph 50/60Hz (other as option)												
Power Factor	0.8 @ full load												
THD	THD ≤ 30 % typ.												
<b>AC Output</b>													
Output Voltage Vac	400Vac 3Ph+N, 50-60Hz +/- 0.001 free running (other as option)												
By pass input voltage	380/400/415Vac +/-10% 3Ph +N (other as option)												
Harmonic Distortion	<2 % with linear load/ <5% with nonlinear load												
Crest factor	3:1												
Overload	105% permanent - 125 % for 10 min. - 150 % for 1min. - 200 % for 100ms												
Static Stability	+/- 1%												
Dynamic Stability	+/-5 % (80% load step) with recovery to 2 % in 40ms												
<b>DC Link</b>													
DC Voltage	110Vdc (90 - 150 )						220Vdc (180 - 300)						
Battery voltage	Floating: 2.27 (VRLA), 2.2÷2.3 (VLA), 1.4÷1.5 (Ni-Cd) V/cell Boost: 2.4÷2.45 (VLA), 1.5÷1.65 (Ni-Cd) V/cell Equalizing: up to 2.35 (VRLA), up to 2.7 (VLA), up to 1.7 (Ni-Cd) V/cell												
Charging current	4	8	12	16	20	4	8	12	16	20	24	30	
<b>Control &amp; Signalisation</b>													
Microprocessor	High Performance 8-Bit Microcontroller with Advanced RISC Architecture												
LCD Pane	Backlit graphic LCD for Meters, Alarm/Status messages, History events & Parameters Settings (password protected)												
Signalling LED	Inverter normal (green), Inverter fault (red), Rectifier normal (green), Rectifier fault (red)												
Acoustic Signa	Buzzer												
MIMIC Panel	Principle block diagram of the UPS with 9 integrated LED												
Volt free signalling contacts	AC input supply failure, Rectifier failure, DC voltage LOW/HI, Battery discharging, Battery disconnected, Inverter failure, Inverter overload, Inverter over temperature, AC output voltage LOW/HI, Ventilation failure, DC hearth fault (option)												
<b>Environmental conditions</b>													
Operating Temperature	0°C + 40°C not condensing												
Storage Temperature	: -20°C to +70°C												
Relative Humidity	≤ 95% a 40°C												
Altitude	≤ 1000 m without derating												
Audible Noise	< 65 -70 dB (A) at 1 m												
Efficiency At Full Load	≥ 88%												
MTBF	140.000 hr at 30 °C												
<b>Mechanical Characteristics</b>													
Cabinet	Free standing, floor mounting, Steel sheet Enclosure - Front door with handle (double rods)												
Steel thickness	Frame 2mm, Door & Sides 1.5mm, Rear & Roof 1.2mm												
Cooling method	Cabinet: Natural - Semiconductor heat sink: Fan assisted (temperature-controlled)												
Access	Front door												
Cable entry	From bottom / Other on request												
Degree of protection	IP20 / Other on request												
Painting / Colour	Epoxy-polyester thermosetting powder coating / RAL 7035												
Dimensions (mm)	W	800	1000	1600	1600	1800	800	1200	1400	1600	1800	1800	2000
	D	800	800	800	800	800	800	800	800	800	800	800	800
	H	1900	1900	1900	1900	1900	1900	1900	1900	1900	1900	1900	1900

#### Standards

- Quality and management system: ISO 9001 – 2008 ISO 14001 – 2004
- Safety: IEC EN 50178 IEC EN 62040 – 2 BS OHSAS 18001-2007
- CE Conformity: Yes
- EMC: IEC EN 61000-6-2, 61000-6-4, 62040-1
- Semiconductor Convertors: IEC EN 60146-1-1, 60146-1-3, 60146-2



SATRON Power Solutions  
 Approach your local SATRON Power Solutions representative for further support.  
 Contact details can be found on:  
[www.satronpower.com](http://www.satronpower.com)